

BOD INCUBATORS 220 - 240 Voltage



## Installation - Operation Manual

SRI3P-2 SRI6P-2 SRI20P-2

## Not for Fly Cultivation

This unit is not designed to hold **fruit flies** (*Drosophila melanogaster*). Use with flies voids the manufacturing warranty and risks damaging the unit.

Other incubator models in the SRIP family are specifically manufactured for fly applications. Talk to your distributor or customer service representative to identify a model compatible with your study or production model.

Pictured on Cover: SRI20P-2 left, SRI6P-2 right

**SRI3P-2**



# Refrigerated BOD Incubators

220 – 240 Voltage

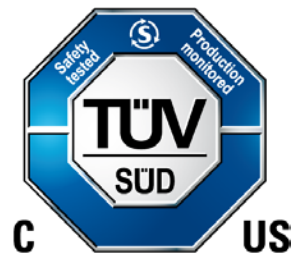
Part Number (Manual) 4861666-2

Revision: November 27, 2017



SHEL LAB is a brand of Sheldon Manufacturing, INC.

## Safety Certifications



These units are CUE listed by TÜV SÜD as incubators for professional, industrial, or educational use where the preparation or testing of materials is done at an ambient air pressure range of 22.14 – 31.3 inHg (75 – 106 kPa) and no flammable, volatile, or combustible materials are being heated.

These units have been tested to the following requirements:

CAN/CSA C22.2 No. 61010-1:2012

CAN/CSA C22.2 No. 61010-2-010:2004 Reaffirmed: 2014-07

UL 61010-1:2012-05

UL 61010A-2-010:2002-03

EN 61010-1:2010

EN 61010-2-010:2014

Supplemented by: UL 61010-2-010:2015

# TABLE OF CONTENTS

<b>INTRODUCTION .....</b>	<b>5</b>
<i>Read this Manual.....</i>	5
<i>Safety Considerations and Requirements .....</i>	5
<i>Contacting Assistance .....</i>	6
<i>Engineering Improvements.....</i>	6
<i>Temperature Reference Sensor Device .....</i>	7
<b>RECEIVING YOUR UNIT .....</b>	<b>9</b>
<i>Inspect the Shipment.....</i>	9
<i>Orientation Photos.....</i>	10
<i>Recording Data Plate Information .....</i>	13
<b>INSTALLATION .....</b>	<b>15</b>
<i>Installation Procedure Checklist .....</i>	15
<i>Required Ambient Conditions.....</i>	16
<i>Required Clearances.....</i>	16
<i>Environmental Disruption Sources.....</i>	16
<i>Power Source Requirements .....</i>	17
<i>Lifting and Handling .....</i>	18
<i>Leveling.....</i>	18
<i>Install Incubator in Location .....</i>	18
<i>Deionized and Distilled Water.....</i>	18
<i>Installation Cleaning.....</i>	19
<i>Install Side Air Ducts in the SRI20P-2.....</i>	19
<i>Shelving.....</i>	20
<i>Access Port Stopper.....</i>	23
<b>GRAPHIC SYMBOLS .....</b>	<b>25</b>
<b>CONTROL PANEL OVERVIEW .....</b>	<b>27</b>
<b>OPERATION.....</b>	<b>29</b>
<i>Theory of Operation .....</i>	29
<i>Put the Incubator into Operation .....</i>	31
<i>Set the Incubator Temperature Set Point.....</i>	32
<i>Set the Over Temperature Limit.....</i>	33
<i>Loading Samples.....</i>	34
<i>Chamber Accessory Power Outlet.....</i>	34
<i>Humidifying the Incubator.....</i>	34
<i>Condensation and the Dew Point .....</i>	35
<i>Turn the Door Open Alarm Off or On.....</i>	36
<b>USER MAINTENANCE.....</b>	<b>39</b>
<i>Cleaning and Disinfecting.....</i>	39
<i>Door Components.....</i>	40
<i>Electrical Components.....</i>	40
<i>Calibrate the Temperature display.....</i>	41
<b>UNIT SPECIFICATIONS .....</b>	<b>45</b>
<i>Weight.....</i>	45
<i>Dimensions.....</i>	45
<i>Capacity .....</i>	45
<i>Shelf Capacity by Weight.....</i>	46
<i>Temperature .....</i>	46
<i>Power.....</i>	46
<b>PARTS AND CONSUMABLES.....</b>	<b>47</b>

# INTRODUCTION

*Thank you for purchasing a SHEL LAB unit. We know you have many choices in today's competitive marketplace when it comes to constant temperature equipment. We appreciate you choosing ours. We stand behind our products and will be here for you if you need us.*

## ***READ THIS MANUAL***

Failure to follow the guidelines and instructions in this user manual may create a protection impairment by disabling or interfering with the unit safety features. This can result in injury or death.

Before using the unit, read the manual in its entirety to understand how to install, operate, and maintain the unit in a safe manner. Keep this manual available for use by all operators. Ensure all operators are given appropriate training before the unit begins service.

## ***SAFETY CONSIDERATIONS AND REQUIREMENTS***

Follow basic safety precautions, including all national laws, regulations, and local ordinances in your area regarding the use of this unit. If you have any questions about local requirements, please contact the appropriate agencies.

### **SOPs**

Because of the range of potential applications, this unit can be used for, the operator or their supervisors must draw up a site-specific standard operating procedure (SOP) covering each application and associated safety guidelines. This SOP must be written and available to all operators in a language they understand.

### **Intended Applications and Locations**

The incubators are intended for constant temperature, non-humidified general incubation applications in professional, industrial, and educational environments. The units are not intended for use at hazardous or household locations.

### **Power**

Your unit and its recommended accessories are designed and tested to meet strict safety requirements.

- The unit is designed to connect to a power source using the specific power cord type shipped with the unit.
- Always plug the unit power cord into a protective earth grounded electrical outlet conforming to national and local electrical codes. If the unit is not grounded properly, parts such as knobs and controls can conduct electricity and cause serious injury.
- Do not bend the power cord excessively, step on it, or place heavy objects on it.
- A damaged cord can be a shock or fire hazard. Never use a power cord if it is damaged or altered in any way.
- Use only approved accessories. Do not modify system components. Any alterations or modifications to your unit not explicitly authorized by the manufacturer can be dangerous and will void your warranty.

## ***CONTACTING ASSISTANCE***

Phone hours for Sheldon Technical Support are 6 am – 4:30 pm Pacific Coast Time (west coast of the United States, UTC -8), Monday through Friday. Please have the following information ready when calling or emailing Technical Support: the **model number** and the **serial number** (see page 13).

EMAIL: support@sheldonmfg.com

PHONE: 1-800-322-4897 extension 4, or (503) 640-3000

FAX: (503) 640-1366

Sheldon Manufacturing, INC.

P.O. Box 627

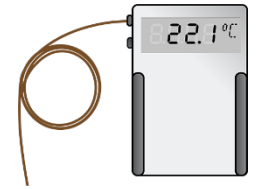
Cornelius, OR 97113

## ***ENGINEERING IMPROVEMENTS***

Sheldon Manufacturing continually improves all of its products. As a result, engineering changes and improvements are made from time to time. Therefore, some changes, modifications, and improvements may not be covered in this manual. If your unit's operating characteristics or appearance differs from those described in this manual, please contact your SHEL LAB dealer or customer service representative for assistance.

## *TEMPERATURE REFERENCE SENSOR DEVICE*

**Must be purchased separately**



**Temperature Reference**

A reference sensor device is required for calibrating the incubator temperature display.

Reference devices must meet the following standards:

- Accurate to at least 0.1°C

The device should be regularly calibrated, preferably by a third party.

### **Temperature Probes**

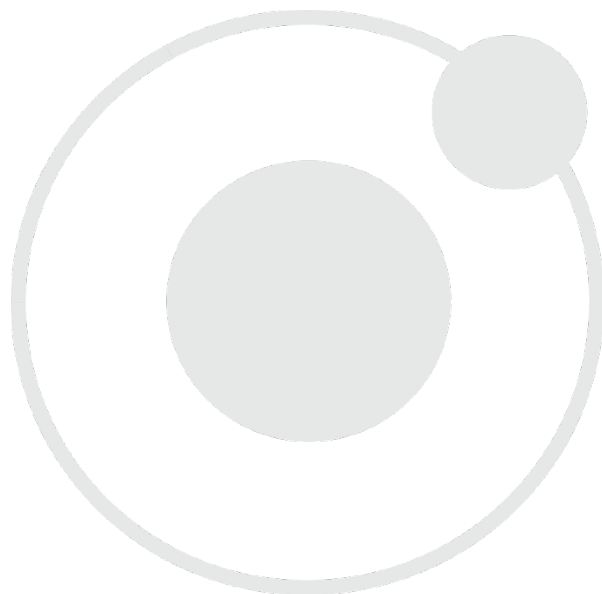
Use a digital device with wire thermocouple probes that can be introduced into the incubation chamber through the unit access port. Select thermocouples suitable for the application temperature you will be calibrating at.

### **Why Probes?**

Reference readings taken outside the chamber using wire temperature probes avoid chamber door openings. Openings disrupt the chamber temperature. Each disruption requires **a minimum 1-hour wait** to allow the atmosphere to re-stabilize before continuing.

### **No Alcohol or Mercury Thermometers**

Alcohol thermometers do not have sufficient accuracy to conduct accurate temperature calibrations. **Never place a mercury thermometer in the incubation chamber!** Always use thermocouple probes.





# RECEIVING YOUR UNIT

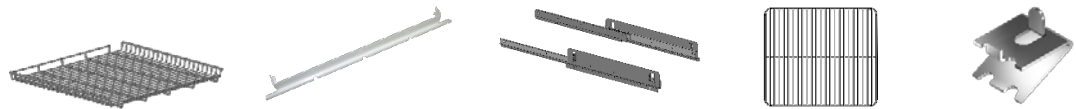
## INSPECT THE SHIPMENT

- When a unit leaves the factory, safe delivery becomes the responsibility of the carrier.
- **Damage sustained during transit is not covered by the manufacturing defect warranty.**
- Save the shipping carton until you are certain that the unit and its accessories function properly.

When you receive your unit, inspect it for concealed loss or damage to its interior and exterior. If you find any damage to the unit, **follow the carrier's procedure for claiming damage or loss.**

1. Carefully inspect the shipping carton for damage.
2. Report any damage to the carrier service that delivered the unit.
3. If the carton is not damaged, open the carton and remove the contents.
4. The unit should come with an Installation and Operation Manual.
5. Verify that the correct number of accessory items have been included.

Model	Shelves (Med.)	Shelf Mounts	Shelf Mounts	Shelf (Small)	Shelf Clips
SRI3P				2	8
SRI6P	2	4 Standard Brackets			
SRI20P	5	8 Standard Brackets	2 Sliding Brackets		



Model	Leveling Feet	Power Cord	Humidification Kit	Side Air Duct Panels
SRI3P	4	1		
SRI6P	4	1		
SRI20P	4	1	1	2



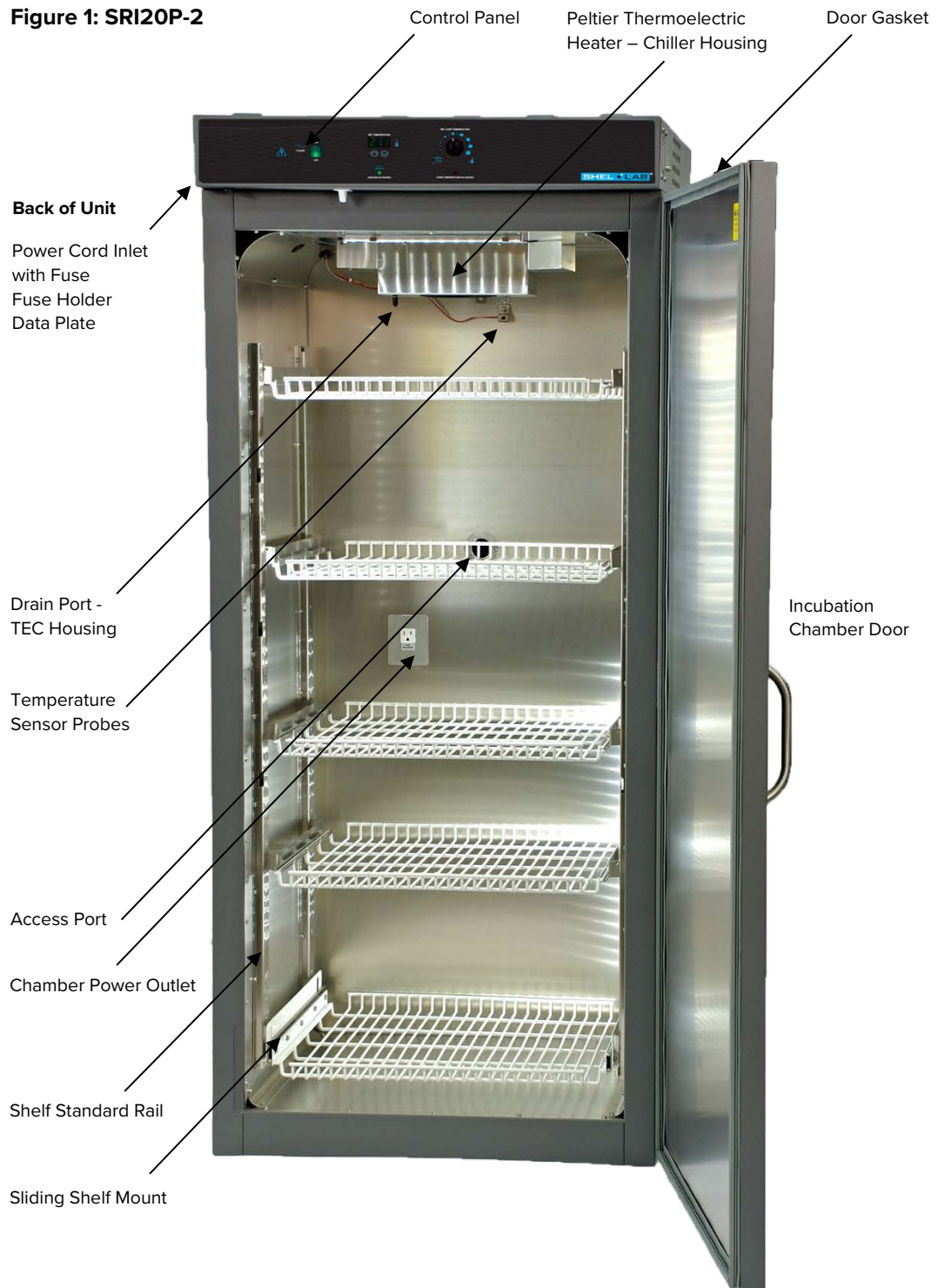
6. The incubator ships with a rubber stopper ins the access port inside the incubation chamber. Verify the presence of the stopper.
7. Carefully check all packaging for accessories before discarding.



# RECEIVING YOUR UNIT

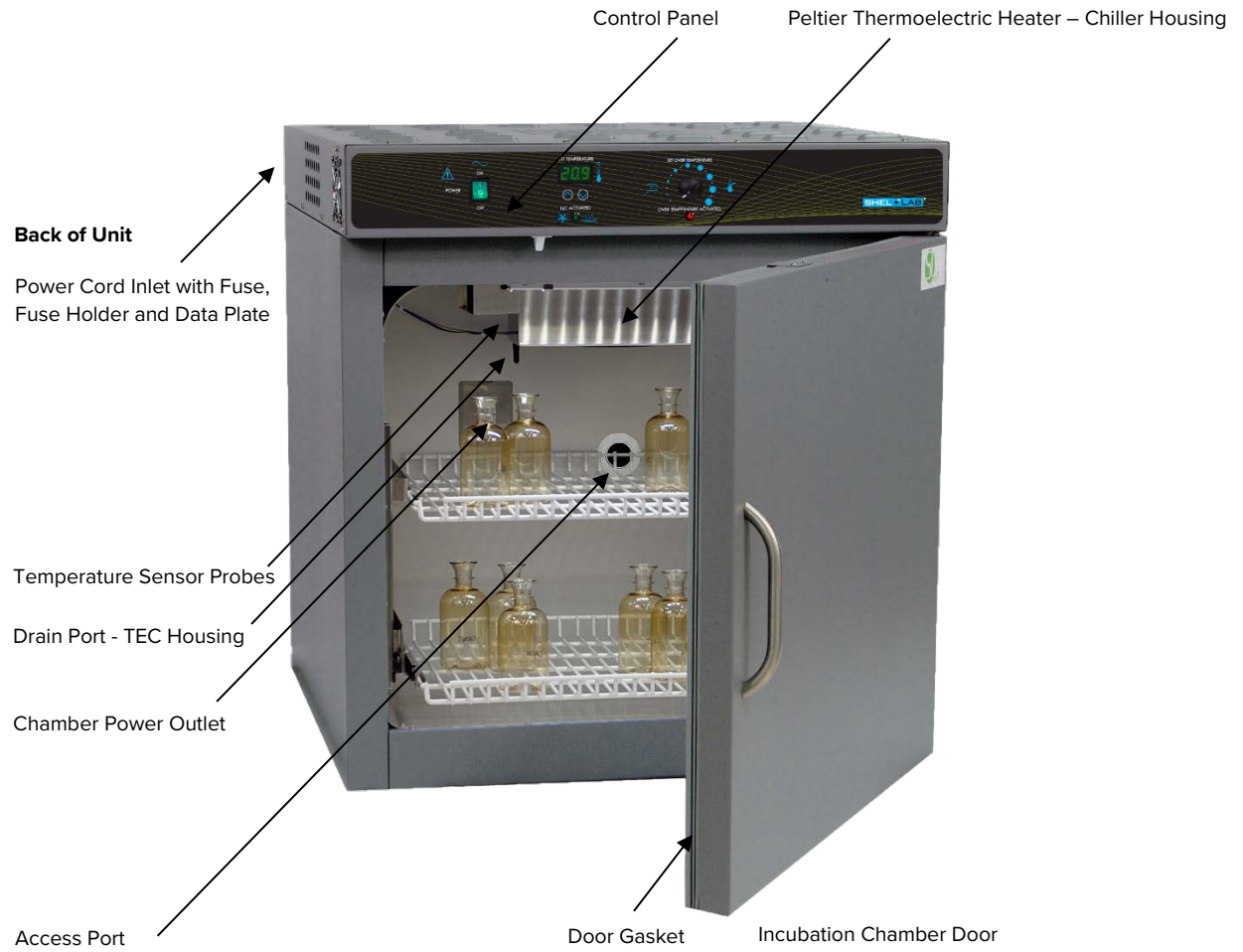
## ORIENTATION PHOTOS

**Figure 1: SRI20P-2**



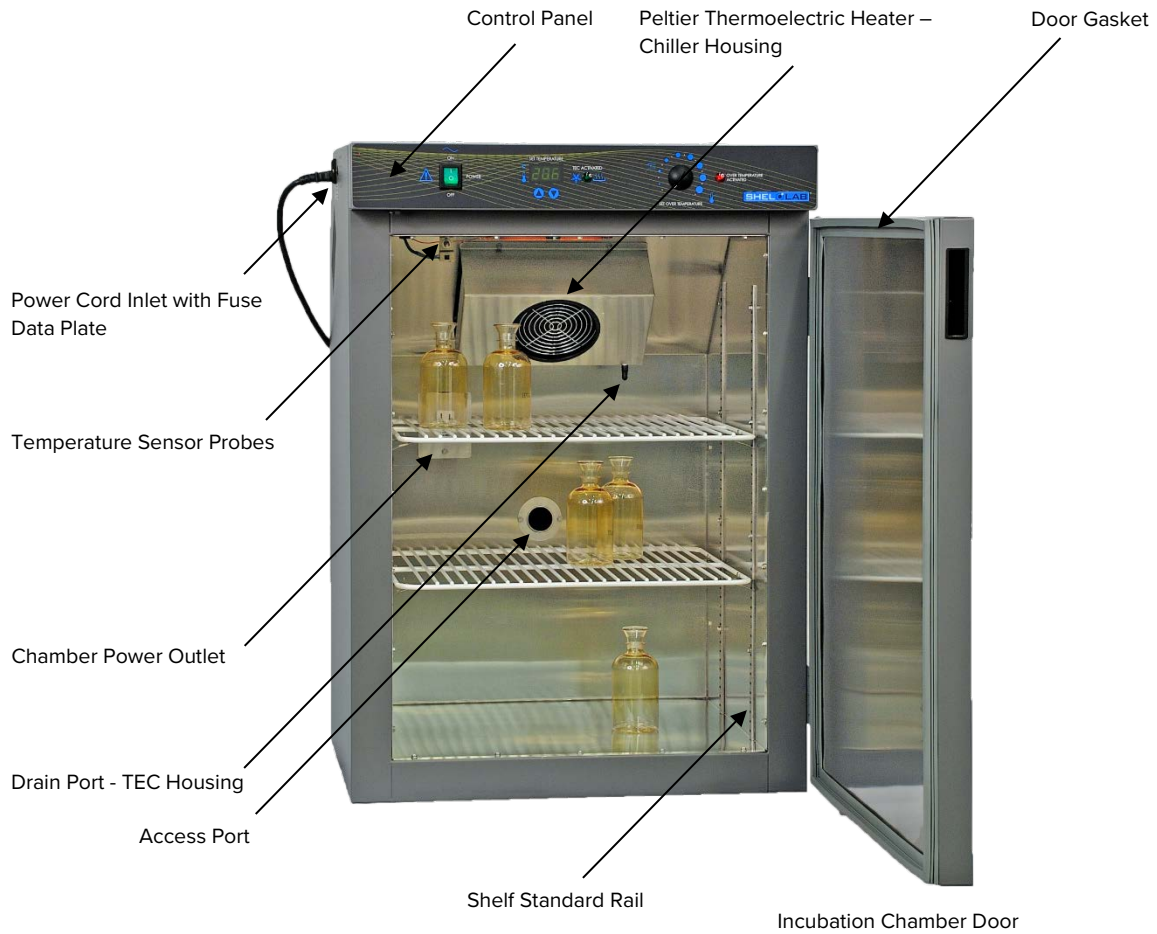
# RECEIVING YOUR UNIT

Figure 2: SRI6P-2



# RECEIVING YOUR UNIT

**Figure 3: SRI3P-2**



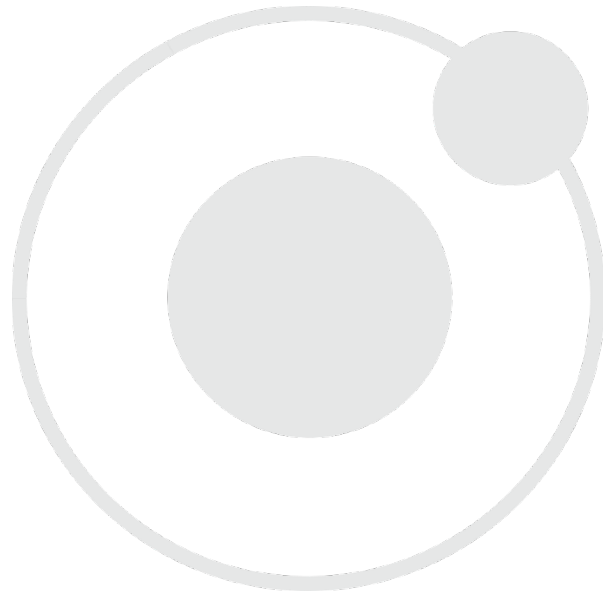
# RECEIVING YOUR UNIT

## *RECORDING DATA PLATE INFORMATION*

The data plate contains the incubator **model number** and **serial number**. Tech Support will need this information during any support call. Record it below for future reference.

- The data plate is located on the left exterior wall of the incubator, toward the back and just above the power cord inlet.

Model Number	
Serial Number	



## ***INSTALLATION PROCEDURE CHECKLIST***

Carry out the procedures and steps listed below to install the incubator in a new workspace location and prepare it for use. All procedures are found in the Installation section of this manual.

### **Pre-Installation**

- ✓ Check that the required ambient condition for the unit are met, page 16
- ✓ Check that the spacing clearance requirements are met, page 16
  - Unit dimensions may be found on page 41
- ✓ Check for performance-disrupting heat and cold sources in the environment, page 16
- ✓ Check that a suitable electrical outlet and power supply is present, page 17

### **Install the Incubator in a suitable workspace location**

- ✓ Review the lifting and handling instructions, page 18
- ✓ Make sure the incubator is level, page 18
- ✓ Install the incubator in its workspace location, page 18

### **Set up the Incubator for use**

- ✓ Clean and disinfect the unit and shelving (recommended), page 19
- ✓ SRI20P-2 only: Install the side air ducts inside the incubation chamber, page 19
- ✓ Install the shelving, page 20
- ✓ Verify the stopper has been installed in the access port, page 23

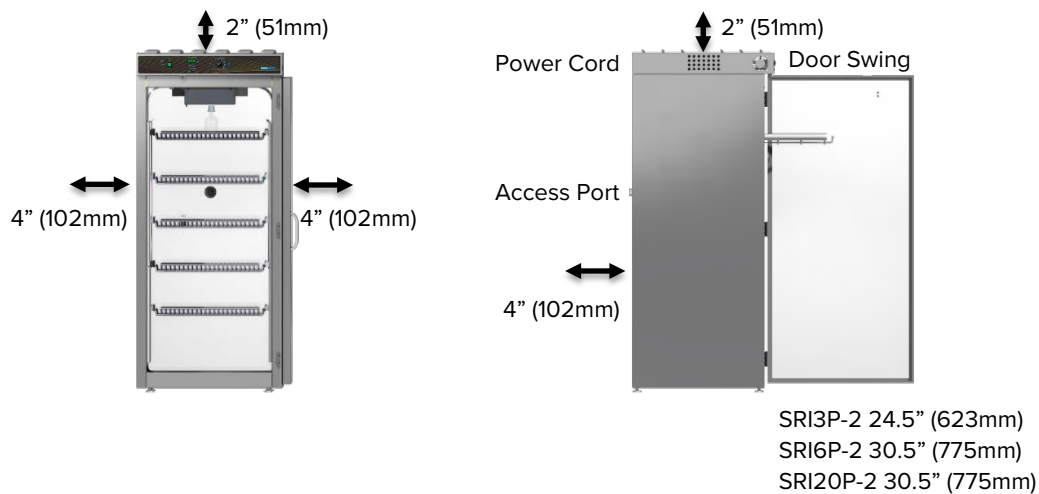
# INSTALLATION

## ***REQUIRED AMBIENT CONDITIONS***

These units are intended for use indoors, at room temperatures between **15°C and 30°C (59°F and 86°F)**, at no greater than **80% Relative Humidity** (at 25°C / 77°F). Operating these units outside of these conditions may adversely affect its incubator temperature stability and effective operating range.

## ***REQUIRED CLEARANCES***

These clearances are required to provide air flows for ventilation and cooling.



**4 inches (102mm)** of clearance is required on the sides and back.

**2 inches (51mm)** of headspace clearance between the top of the unit and any overhead partitions.

## ***ENVIRONMENTAL DISRUPTION SOURCES***

Consider proximate environmental factors that can affect the chamber temperature and atmospheric integrity when selecting a location to install the unit:

- Ovens, autoclaves, and any device that produces significant radiant heat
- High-traffic areas
- Direct sunlight
- Heating and cooling ducts or other sources of fast-moving air currents



# INSTALLATION

## POWER SOURCE REQUIREMENTS

When selecting a location for the unit, verify each of the following requirements is satisfied.

**Power Source:** The power source for the unit must match the voltage and match or exceed the ampere requirements listed on the unit data plate. These units are intended for **220 - 240V 50/60 Hz** applications at the following amperages:

Model	Amperage
SRI3P-2	3.0 Amps
SRI6P-2	3.0 Amps
SRI20P-2	3.5 Amps

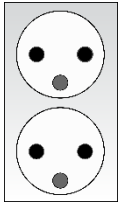
- **Supplied voltage must not vary more than 10% from the data plate rating.** Damage to the unit may result if the supplied voltage varies more than 10%.
- The wall power source must be protective earth grounded.
- Use a separate circuit to prevent loss of the unit due to overloading or circuit failure.
- **The recommended wall circuit breakers for these units are 16 amps.**
- The wall power source must conform to all national and local electrical codes.

**Power Cord:** The unit must be positioned so that all end-users can quickly unplug the cord in the event of an emergency.

- Each unit is provided with a **230V, 10 Amp, EUR16P, CEE 7/7, 2.5 meters (8.2ft)**. always use this cord or an identical replacement.

**Fuses:** These units each ship with a fuse installed in the power cord inlet and a second fuse installed in an adjacent fuse holder.

- Both fuses must be installed and intact for the unit to operate.
- Always find and fix the cause of a blown fuse prior to putting the unit back into operation.
- Fuse type
  - T6.3A, 250V, 5X20MM



Standard CEE7/7 wall socket.



# INSTALLATION

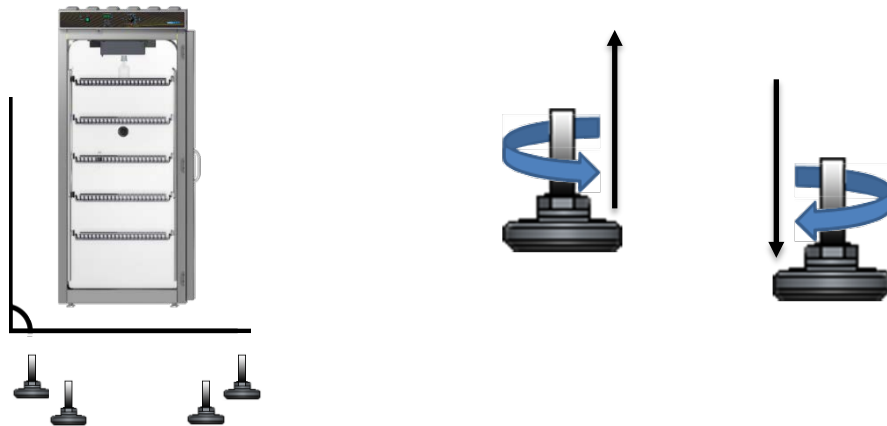
## ***LIFTING AND HANDLING***

The unit is heavy. Use appropriate lifting devices that are sufficiently rated for these loads. Follow these guidelines when lifting the unit.

- Lift the unit only from its bottom surface.
- Doors, handles, and knobs are not adequate for lifting or stabilization.
- Restrain the unit completely while lifting or transporting so it cannot tip.
- Remove all moving parts, such as shelves and trays, and lock doors in the closed position during transfers to prevent shifting and damage.

## ***LEVELING***

Install the leveling feet in the 4 corner holes on the bottom of the unit. The unit must be level and stable for safe operation.



---

**Note:** To prevent damage when moving the unit, turn all 4 leveling feet so that the leg of each foot sits inside the unit.

---

## ***INSTALL INCUBATOR IN LOCATION***

Install the unit in a workspace location that meets the criteria discussed in the previous entries of the Installation section.

## ***DEIONIZED AND DISTILLED WATER***

**Do not use deionized water** to clean or humidify the incubator. Use of deionized water may corrode metal surfaces and voids the warranty. The manufacturer recommends the use of distilled water in the resistance range of 50K Ohm/cm to 1M Ohm/cm, or a conductivity range of 20.0 uS/cm to 1.0 uS/cm, for cleaning and humidifying applications.

# INSTALLATION

## *INSTALLATION CLEANING*

Cleaning and disinfecting the incubation chamber during installation reduces the chance of microbiological contamination. The unit was cleaned and disinfected at the factory. However, the unit may have been exposed to contaminants during shipping. Additionally, the factory procedure may not meet the standards of your institutional protocols. Please see the [Cleaning and Disinfecting](#) entry on page 39 in the User Maintenance section for information on how to clean and disinfect without damaging the chamber.

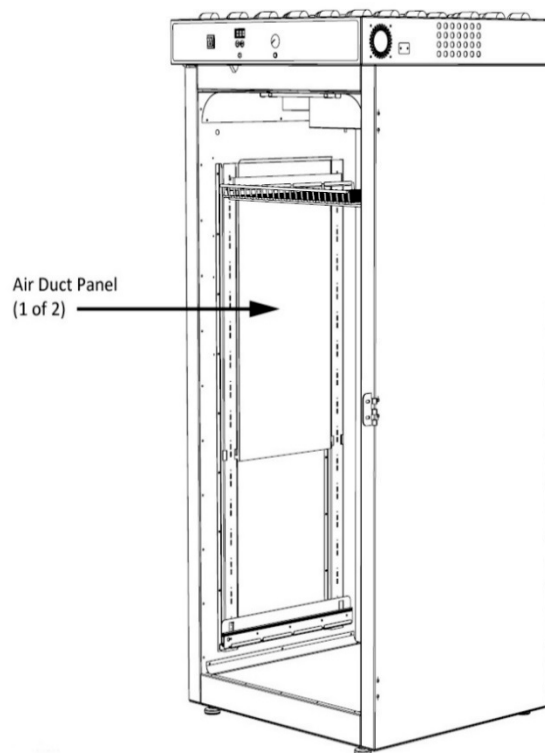
- Remove all wrappings and coverings from shelving prior to cleaning and installation.

## *INSTALL SIDE AIR DUCTS IN THE SRI20P-2*

Hang the two side panels included with the SRI20P on the chamber side walls. These air duct panels play an important role maintaining even heat distribution inside the long incubation chamber of the SRI20P.

Not installing both air duct panels **may adversely impact the chamber temperature uniformity.**

1. Place the hooks on the top and bottom corners of each panel into the inside slots on the shelf standard mounting rails.



**Figure 4: SRI20P Air Duct Panel**

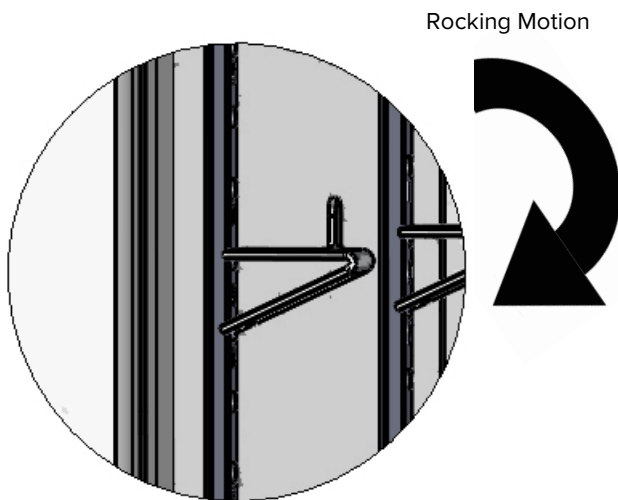
The SRI3P and SRI6P incubator do not require side ducts.

# INSTALLATION

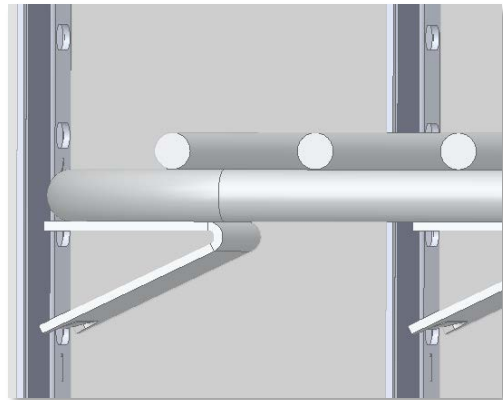
## *SHELVING*

### **SRI3P-2 Shelf Installation**

1. Install 4 shelf clips for each shelf in the shelf standard mounting rails.
  - a. Squeeze each clip and hold.
  - b. Insert the top tab first, and then the bottom tab using a rocking motion.
  - c. 4 clips per shelf.
2. Place 1 shelf on the 4 clips.



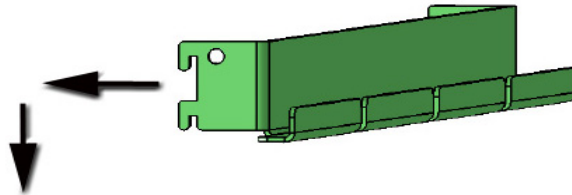
**Figure 5: SRI3P Shelf Clip Installed**



**Figure 6: SRI3P Shelf Installed**

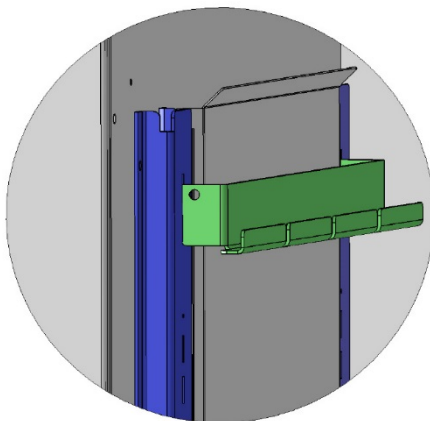
# INSTALLATION

## SRI6P and SRI20P Standard Shelving Installation

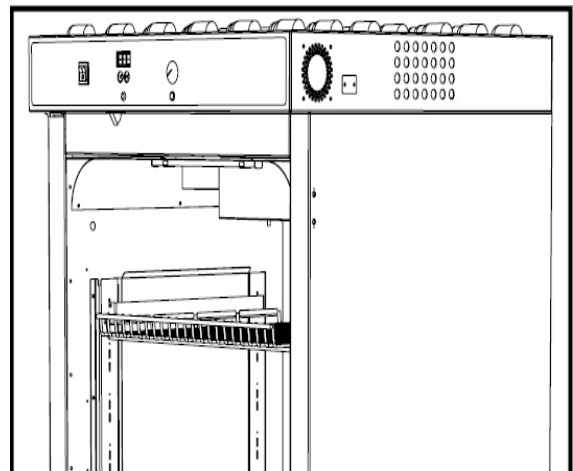


**Figure 7: Standard Shelf Mounting Bracket Installation**

1. Insert bracket tabs into the shelf standard slots in the incubation chamber.
2. Slide the bracket down so the tabs sit securely in the mounting slots.
3. Repeat the process on the opposite side of the chamber with the second mounting bracket.
4. Place 1 shelf on the 2 installed mounting brackets.



**Figure 8: Standard Mounting**

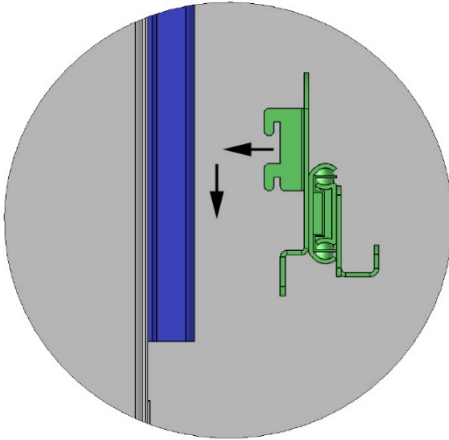


**Figure 9: Standard Shelf Installed**

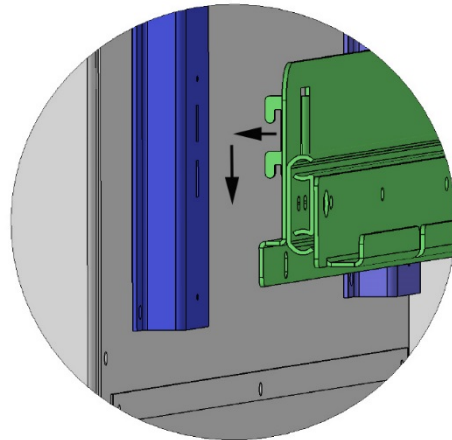
# INSTALLATION

## SRI6P and SRI20P Sliding Shelf Installation

The SRI6P does not come with a sliding shelf. Sliding shelf mounts for the SRI6P must be purchased separately.

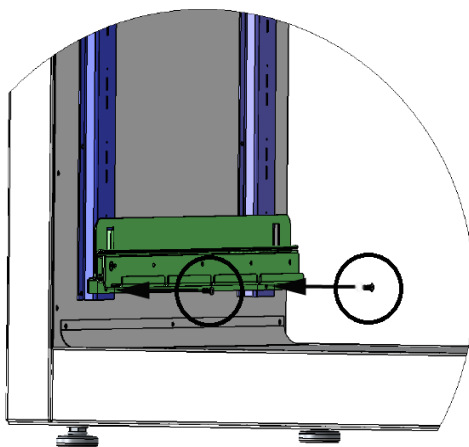


**Figure 10: Sliding Shelf Mounting Bracket Installation**

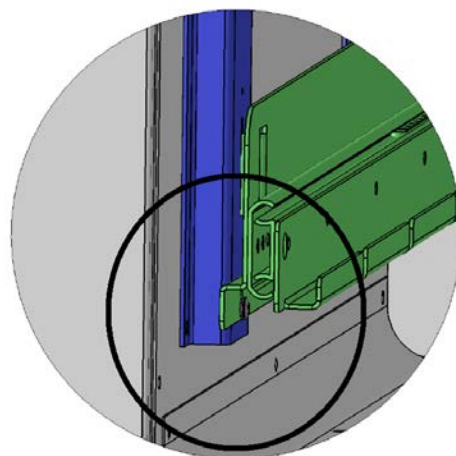


**Figure 11: Sliding Shelf Mounting Bracket Installation**

1. Insert the sliding bracket tabs into the mounting slots on the shelf standard rails. See Figure 10 and Figure 11.
2. Slide the bracket down so the tabs sit securely in the slots.
3. Screw in the included screws on the front and back of the flange located on the bottom of the bracket. See Figure 12 and Figure 13.
4. Repeat the process on the opposite side of the chamber with the second sliding mounting bracket.
5. Place 1 shelf on the 2 sliding brackets.



**Figure 12: Sliding Mounting Bracket Screws**



**Figure 13: Sliding Mounting Bracket Front Screw Installed**

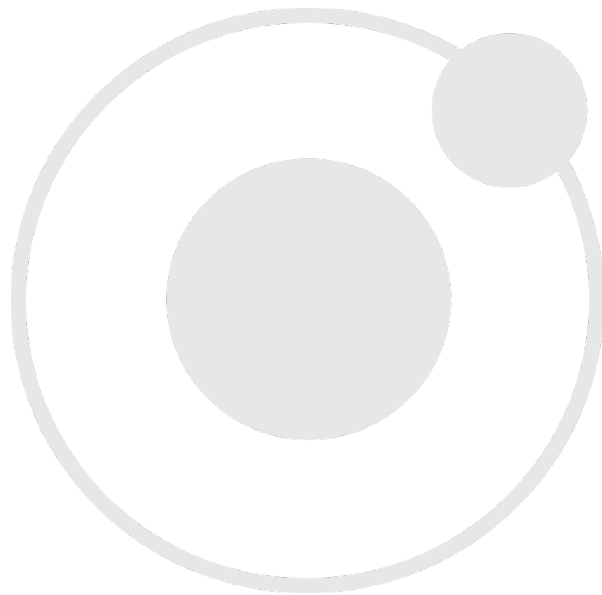
# INSTALLATION

## *ACCESS PORT STOPPER*

Each incubator ships with a rubber stopper installed in the access port located in the back of the incubation chamber.

- The stopper should **always be installed inside** the chamber to obtain the best temperature uniformity and prevent condensation from forming inside the port. Do not install on the outside of the port on the back of the unit.
- Wires for thermocouples and other sensor probes may be introduced into the chamber through the access port. The stopper may be put in place over the wires.





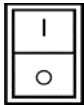






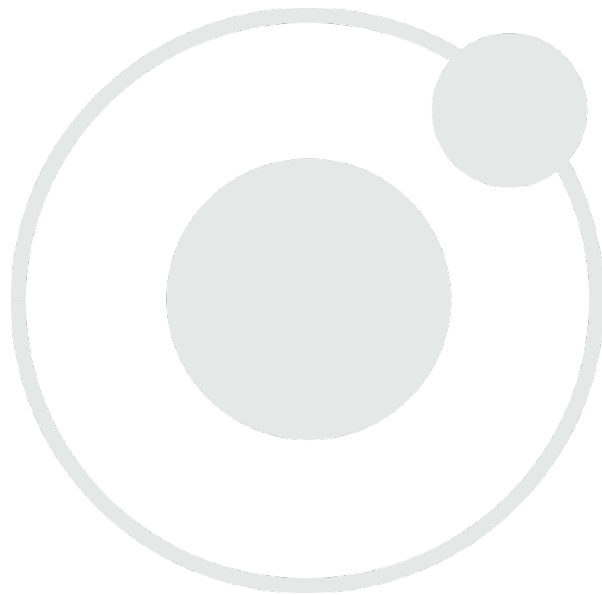




# GRAPHIC SYMBOLS

The unit is provided with multiple graphic symbols on its exterior. The symbols identify hazards and the functions of the adjustable components, as well as important notes in the user manual.

Symbol	Definition
	Consult the user manual. Consulter le manuel d'utilisation
	Temperature display Indique l'affichage de la température
	Over Temperature Limit system Thermostat température limite contrôle haute
	AC Power Repère le courant alternatif
	I/ON O/OFF I indique que l'interrupteur est en position marche. O indique que le commutateur est en position d'arrêt.
	Protective earth ground Terre électrique
	Adjusts UP and DOWN Ajuster la température de l'incubateur vers le haut et vers le bas
	Manually adjustable Indique un réglage manuel
	Recycle the unit. Do not dispose of in a landfill. Recycle l'unité. Ne jetez pas dans une décharge.



# CONTROL PANEL OVERVIEW



Figure 14: Control Panel SRI6P SRI20P Top | SRI3P Bottom

## Power Switch

The switch illuminates when in the ( I ) ON position.



## Set Temperature Display and Controls

During normal operations, this display shows the current incubation chamber air temperature accurate to 0.1°C. The Up and Down buttons are used to change display modes and then input a new temperature set point or a calibration adjustment. The display blinks continually while in its set point or calibration adjustment modes, preceded by an “SP” for Set Point or “C O” for Calibration Offset.



These controls are also used to turn the Door Open Alarm off or on.

## Heating and Cooling Indicator

The green light located next to the label TEC ACTIVATED illuminates whenever the Peltier TEC-H device is actively cooling or heating the chamber. This light will illuminate frequently during normal operations as the incubator makes minute adjustments.



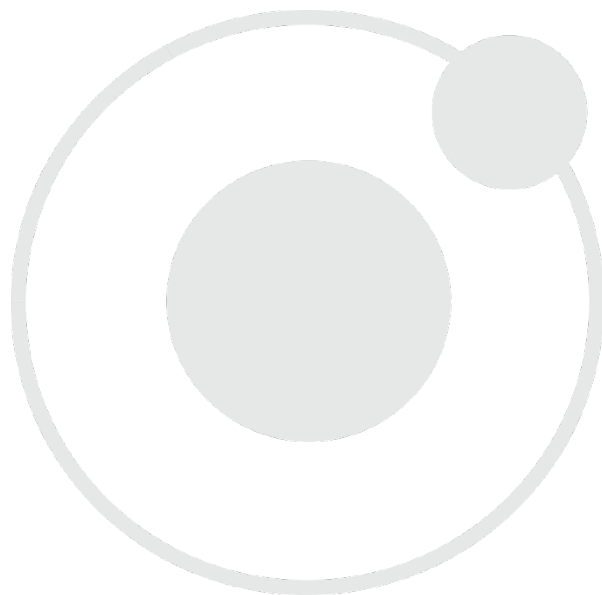
## Set Over Temperature

The Set Over Temperature dial sets the temperature limit at which the unit cuts off heating in the incubation chamber. For more details, please see the [Over Temperature Limit System](#) description in the Theory of Operations (page 30).



The red OVER TEMPERATURE ACTIVATED illuminates when the Over Temperature Limit system cuts power to the Peltier TEC heating circuits. Under normal operating conditions this indicator should never turn on.





## *THEORY OF OPERATION*

The SRIP incubator family provides stable and uniform incubation environments suitable for biological oxygen demand studies, including at or below standard room temperature. Additionally, these units consume significantly less electricity and produce less waste heat than traditional refrigerated incubators.

### **Peltier Heating and Cooling**

To achieve a stable chamber temperature, refrigerated incubators normally rely on a near-continual competition between a refrigeration compressor and a conventional resistive heating element. SRIP units employ a thermoelectric cooling-and-heating (TEC-H) device, which operates using the Peltier effect to supply heating or cooling as needed.

The effect: A current between two touching but dissimilar conductor plates produces a heat flow from one plate to the other. The direction of this gradient can be flipped by reversing the direction of the current. The sandwiched TEC-H conductors effectively operate as a reversible high-efficiency heat pump. Compared to a compressor–element pairing, Peltier effect devices consume far less electricity and generate significantly less waste heat with a corresponding reduction in cooling demand placed on laboratory climate control systems.

### **Control**

The incubator microprocessor controller monitors the air temperature of the incubation chamber using a solid-state sensor probe located in the chamber airstream. When the controller detects a temperature deviation from the current set point, it pulses power to the TEC-H device to add or remove heat from the chamber. Heated or chilled air is circulated through the chamber using a circulation fan attached to the TEC-H.

The controller employs proportional-integral-derivative (PID) analytical feedback-loop functions when measuring and controlling the chamber temperature. The intensity of PID-controlled heating and chilling is proportional to the difference between the measured chamber temperature and the set point. The frequency of heating or chilling pulses is derived from the rate of change in the difference. Integrator feedback slows the rate of heating or chilling as the chamber temperature approaches the set point, preventing overshoots.

During normal operations, with the chamber door closed, the Peltier device pulses heat or cold to the chamber almost continuously, as indicated by a flickering of the green TEC device pilot light. These are short, low-power pulses to compensate for deviations of a hundredth degree Celsius ( $\pm 0.01^{\circ}\text{C}$ ).

As a solid-state device, the Peltier TEC-H offers significant maintenance savings cost. The device can be replaced by a service technician using a screwdriver and a nut driver. It does not require a certified refrigeration compressor specialist with refrigeration tools, replacement coolant fluid, and does not contain a system of easily damage, pressurized fluid vessels.

## Door Alarm

The incubator is equipped with a magnetic induction door alarm, which activates when the door is open for 60 seconds. When the alarm is active, an audio alert will sound and the temperature display will flash. Closing the door will temporarily turn off the alarm. The alarm may be set to off indefinitely using the **Turn Alarm Off / On** procedure on page 36.

## Accessory Waste Heat

Powered accessories producing significant waste heat when active inside the incubation chamber may disrupt the incubator temperature stability and uniformity. Such equipment may also heat the chamber to the point the unit cannot obtain the low end of its specified operating range. Verify powered accessory equipment will not produce excessive waste heat.

## The Over Temperature Limit System (OTL)

The mechanical OTL heating cutoff system monitors the chamber temperature using an independent hydrostatic temperature probe located in the chamber air stream. If the chamber temperature is higher than the OTL setting, the system prevents power from flowing to the Peltier TEC-H device in the direction that adds heat to the chamber. In other words, the Peltier chiller – heater will not heat while the OTL system is active, but it should continue to cool the chamber.

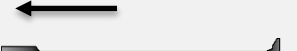
The OTL heating cutoff limit is set **by the end-user**, normally at approximately 1°C above the application temperature. It is intended to help safeguard samples and prevent runaway heating in the event of a hardware failure or a heat spike generated inside or outside of the incubator chamber.

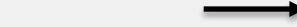
The OTL cutoff cannot prevent a rise in heat caused by a complete failure of the Peltier TEC-H itself. With the loss of the refrigeration function, the chamber temperature will rise to the ambient room temperature, plus 1 or 2°C.

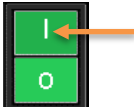
# OPERATION

## *PUT THE INCUBATOR INTO OPERATION*


Carry out the following steps and procedures to put the unit into operation after installing it in a new workspace environment.

1.  Attach the power cord that came with the unit to the power inlet receptacle on the side of the incubator.

2.  Plug the power cord into the workspace electrical supply outlet.

3.  Place the incubator **Power Switch** in the ON ( I ) position.

- The switch illuminates
- The Temperature display illuminates

4.  **Set the Temperature the Set Point** to your incubation application temperature.

- See page 32

5.  **Set the Over Temperature Limit.** See page 33.

The incubator must be heated **and stable** at your application temperature prior to performing this procedure.



Wait 8 Hours

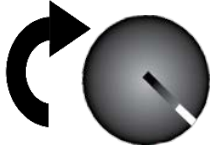
Allow the unit to run 8 hours (overnight) prior to:

- **Loading Samples**, page 34
- Verifying the accuracy or calibrating the incubator temperature display.

End of procedure

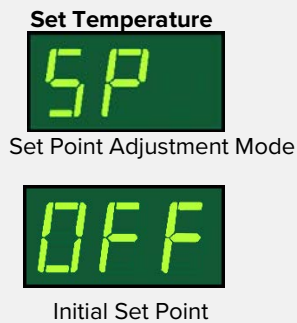
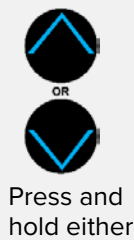
## SET THE INCUBATOR TEMPERATURE SET POINT

1. Set the OTL control to its maximum setting, if not already set to max.



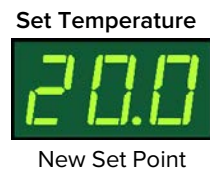
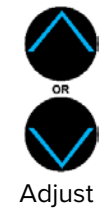
Note: This prevents the heating cutoff system from interfering with setting a higher temperature.

2. Navigate to the Temperature Set Point Adjustment mode



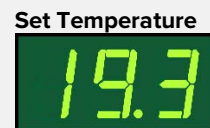
Note: The display automatically exits the adjustment mode after 5 seconds of inactivity on the arrow keys, saving the last shown set point value.

3. Set the Temperature Set Point



Note: To turn an incubator off, set the set point to its lowest setting (OFF).

4. Wait for 5 seconds for the Set Point to save



HEATING ACTIVATED

- The display will stop flashing. The set point is now saved in the controller.
- The display will revert to showing the current chamber air temperature, heating or passively cooling to match the new set point.

See the next page for how to set the Over Temperature Limit heating cutoff.

End of procedure



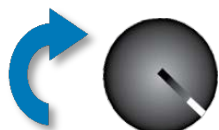
# OPERATION

**Note:** Test the OTL heating cutoff system at least once per year for functionality.

## ***SET THE OVER TEMPERATURE LIMIT***

The incubator must be operating at your incubation application temperature and must be stable for at least 1 hour prior to setting the OTL.

**1. Set OTL control to its maximum setting, if not already set to max.**



**2. Turn the dial counterclockwise until the red Over Temperature Limit Light illuminates.**



**3. Slowly turn the dial clockwise until the OTL Activated light turns off.**



- The Over Temperature Limit is now set approximately 1°C above the current incubator air temperature.

**4. Leave the OTL dial set just above the activation point.**



**Optional: Turn the dial slightly to the left.**



- This sets the OTL cutoff threshold nearer to the current incubator air temperature.

If the OTL is sporadically activating, you may turn the dial slightly to the right (clockwise).

If the OTL continues activating, check for ambient sources of heat or cold that may be adversely impacting the unit temperature stability. Check if any powered accessories in the workspace chamber are generating heat. If you can find no sources of external or internal temperature fluctuations, contact Tech Support or your distributor for assistance.

End of Procedure

## *LOADING SAMPLES*

Place items on the shelves inside the incubation chamber as evenly spaced as possible. Proper spacing allows for maximum air circulation and a high degree of temperature uniformity. Leave 1 inch (25mm) between sample containers and the chamber walls.

## *CHAMBER ACCESSORY POWER OUTLET*

The incubator is provided with an accessory outlet located inside the chamber on the back interior wall. The power switch on the main control panel controls power to this outlet.

- The outlet is intended to power low-draw equipment such as magnetic stirrers or a volatile compounds scrubber fan.
- **Do not attach equipment drawing more than 1 amp to the outlet.**

### **Waste Heat**

Accessory equipment may generate heat in the incubation chamber. This can affect the temperature performance of the incubator.

## *HUMIDIFYING THE INCUBATOR*

Closed bottle BOD applications do not require humidification.

Placing only a small number of open or breathable media containers in the incubator chamber may lead to excessive drying of sample media. Unusually dry environmental conditions may also contribute to sample drying.

### **Humidification Kit**

Sheldon Manufacturing offers an optional humidity collection pan and tubing accessory kit: **Part Number 9900708**. The kit redirects moisture that normally condenses on the heat sink fins of the Peltier TEC heating and cooling device, and uses it to humidify the incubator.

1. Connect the tubing that comes with the kit to the port on the bottom of the Peltier duct cover.
  2. Run the tubing down the back of the incubator behind the shelves, and secure the end of the tubing inside the pan.
- The pan is supplied with a copper slug to help prevent microbial contamination.

The humidification kit is intended for use while running **small loads**.

SRI20P incubators ship with the humidification kit as a standard accessory item.

## ***CONDENSATION AND THE DEW POINT***

Condensation takes place whenever the humidity level in the incubator chamber reaches the dew point. The dew point is the level of humidity at which the air cannot hold more water vapor. The warmer the air, the more water vapor it can hold.

As the level of humidity rises in an incubation chamber, condensate will first appear on surfaces that are cooler than the air temperature. Near the dew point, condensate forms on any item or exposed surface even slightly cooler than the air. When the dew point is reached, condensate forms on nearly all exposed surfaces.

Ambient relative humidity exceeding 80% or overloading the incubation chamber with open or breathable sample containers will likely result in condensation in the chamber, possible leaks around the incubator. This may cause corrosion damage if allowed to continue for any significant length of time.

Managing condensation primarily depends on either lowering the humidity level or increasing the air temperature in the incubator chamber.

---

**Note:** Rising or falling air pressure from the weather will adjust the dew point up and down in small increments. If the relative humidity in the incubation chamber is already near the dew point, barometric fluctuations may push it across the dew threshold.

**Note:** Thin air at higher altitudes holds less humidity than the denser air found at or near sea level.

---

If excessive condensate has appeared in the incubation chamber, dry the chamber interior and check the following.

- Check the door gaskets for damage, wear, or signs of brittleness or dryness. Arrange for replacement of the gaskets if damaged or excessively worn.
- Verify the chamber access port is closed. The black, rubber shipping cap that came with the unit should be installed on the inside of the incubator in the chamber.
- Make sure samples on the shelves are evenly spaced to allow for good airflow.
- Ensure the chamber door is closing and latching properly.
- Are frequent or lengthy chamber door openings causing significant temperature disruptions and chilling the chamber surfaces? If so, reduce the number of openings.
- Are there too many open or “breathable” containers of evaporating sample media in the chamber? If so, reduce the number of open sample containers.
- Does the ambient humidity in the room exceed the stated operating range of 80% relative environmental humidity? If so, lower the room humidity.
- Is the incubator exposed to an external flow of cold air such as an air-conditioning vent or a door to a cooler hallway or adjacent room? Block or divert the air, or reposition the unit.

## ***TURN THE DOOR OPEN ALARM OFF OR ON***

The Door Open alarm sounds an audible alarm and causes the temperature display to blink on and off when the door has been open for longer than 60 seconds.

### **Turn the Alarm Off**

The alarm comes from the factory set to On.

#### **1. Navigate to the Temperature Set Point Adjustment mode**



OR



Press and hold either

Set Temperature



Set Point Adjustment Mode



Flashing Set Point

**Note:** The display will automatically exit the adjustment mode after 5 seconds of inactivity on the arrow keys, saving the last shown set point value.

#### **2. Set the Temperature Set Point to Door Off**



Press and Hold

Set Temperature



Door Alarm Off

Press and hold the Up button until the display reads "dO".

#### **3. Wait 5 seconds**



Wait 5 Seconds

Set Temperature



- Door Off will flash 6 times. The display will revert to showing the current chamber air temperature.
- The door alarm is now set to Off. The temperature set point has not been changed.

Continued next page

# OPERATION

## Turn the Door Alarm On

### 1. Navigate to the Temperature Set Point Adjustment mode



OR



Press and hold either

Set Temperature



Set Point Adjustment Mode



Flashing Set Point

**Note:** The display will automatically exit the adjustment mode after 5 seconds of inactivity on the arrow keys, saving the last shown set point value.

### 2. Set the Temperature Set Point to ON (I)



Set Temperature



Door Alarm On

Press and hold the Up button until the display reads "dO".

### 3. Wait 5 seconds



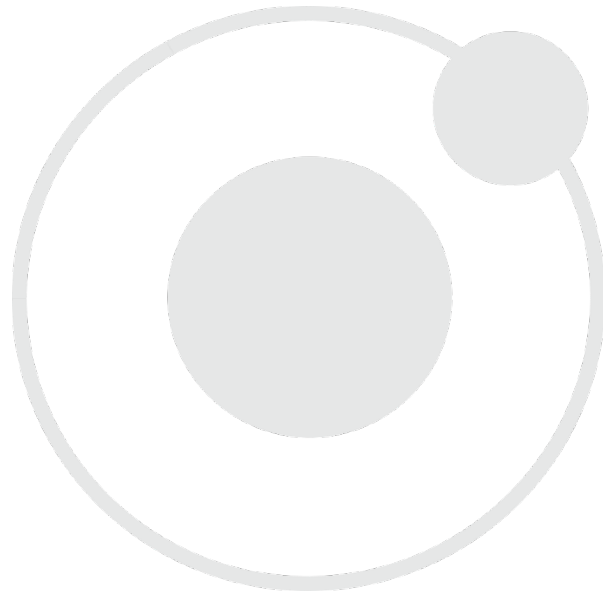
Wait 5 Seconds

Set Temperature



- Door Off will flash 6 times. The display will revert to showing the current chamber air temperature.
- The door alarm is now set to On. The temperature set point has not been changed.

End of procedure



---

**Warning:** Disconnect this unit from its power supply prior to performing maintenance or services.

**Avertissement:** Débranchez cet appareil de son alimentation électrique avant d'effectuer la maintenance ou les services.

---



## ***CLEANING AND DISINFECTING***

If a hazardous material or substance has spilled in the unit chamber, immediately initiate your site Hazardous Material Spill Containment protocol. Contact your local Site Safety Officer and follow instructions per the site policy and procedures.

- Periodic cleaning and disinfection are required.
- Do not use spray on cleaners or disinfectants. These can leak through openings and coat electrical components.
- Consult with the manufacturer or their agent if you have any doubts about the compatibility of decontamination or cleaning agents with the parts of the equipment or with the material contained in it.
- Do not use cleaners or disinfectants that contain solvents capable of harming paint coatings or stainless steel surfaces. **Do not use chlorine-based bleaches or abrasives; these will damage the chamber liner.**

---

**Warning:** Exercise caution if cleaning the unit with alcohol or flammable cleaners. Always allow the unit to cool down to room temperature prior to cleaning and make sure all cleaning agents have evaporated or otherwise been completely removed prior to putting the unit back into service.

**Avertissement:** Soyez prudent lorsque vous nettoyez l'appareil avec de l'alcool ou des produits de nettoyage inflammables. Laissez toujours refroidir l'appareil à la température ambiante avant le nettoyage et assurez-vous que tous les produits de nettoyage se sont évaporés ou ont été complètement enlevés avant de remettre l'appareil en service.

---



### **Cleaning**

1. Disconnect the unit from its power supply.
2. Remove all removable interior components such as shelving and accessories.
3. Clean the unit with a mild soap and water solution, including all corners.
  - **Do not use an abrasive cleaner**, these will damage metal surfaces.
  - **Do not use deionized water to rinse or clean with.**
  - Take special care when cleaning around the temperature sensor probes in the chamber to prevent damage. Do not clean the probes.
4. Rinse with distilled water and wipe dry with a soft cloth.

## **Disinfecting**

For maximum effectiveness, disinfection procedures are typically performed after cleaning. Keep the following points in mind when disinfecting the unit.

- Turn off and disconnect the unit to safeguard against electrical hazards.
- Disinfect the unit chamber using commercially available disinfectants that are non-corrosive, non-abrasive, and suitable for use on stainless steel and glass surfaces. Contact your local Site Safety Officer for detailed information on which disinfectants are compatible with your applications.
- If permitted by your protocol, remove all removable interior accessories (shelving and other non-attached items) from the chamber when disinfecting.
- Disinfect all surfaces in the chamber, making sure to thoroughly disinfect the corners. Exercise care to avoid damaging the sensor probes.

When disinfecting external surfaces, use disinfectants that will not damage painted metal, glass, and plastic

## ***DOOR COMPONENTS***

Periodically, inspect the door latch, trim, catch, and gaskets for signs of deterioration. Failure to maintain the integrity of the door system shortens the life span of the incubator.

## ***ELECTRICAL COMPONENTS***

Electrical components do not require maintenance. If the incubator fails to operate as specified, please contact your distributor or [Technical Support](#) for assistance.



# USER MAINTENANCE

## CALIBRATE THE TEMPERATURE DISPLAY

**Note:** Performing a temperature display calibration requires a temperature reference device. Please see the [Reference Sensor Device entry](#) on page 7 for the device requirements.



Temperature calibrations are performed to match the incubator temperature display to the actual air temperature inside the incubation chamber. The actual air temperature is supplied by a calibrated reference device. Calibrations compensate for long-term drifts in the incubator microprocessor controller as well as those caused by the natural material evolution of the sensor probe in the heated incubator space. Calibrate as often as required by your laboratory or production protocol, or regulatory compliance schedule. Always calibrate to the standards and use the calibration setup required by your industry requirements or laboratory protocol.

### A suggested calibration setup

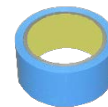
**1.** Introduce the reference device thermocouple sensor probe through the access port on the back of the incubator into the incubation chamber.

**2.** Position the sensor probe head as close as possible to the geometric center point of the chamber. incubation chamber with the probe heads at least 2 inches (51 mm) above the shelving to avoid heatsinking.

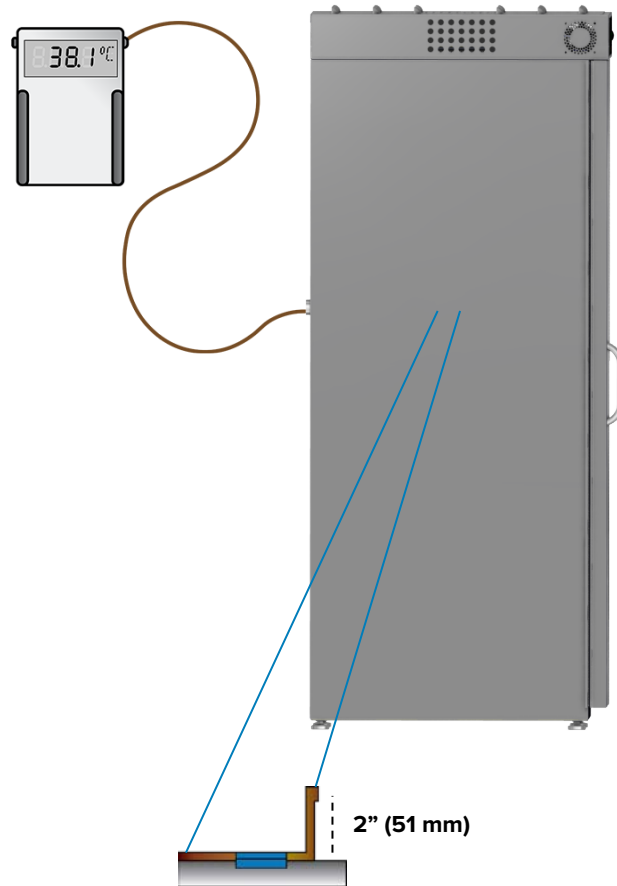
Secure all probes in place with non-stick, heat-resistant tape.

**3.** After securing the probe in position, carefully place the access port stopper in the port over the probe wire. Use non-stick tape to seal any gaps created between the stopper and the port by the probe

**4.** The incubation chamber door must be closed and latched. Failure to do so will prevent an accurate calibration.



**Heat-resistant non-stick tape recommended**

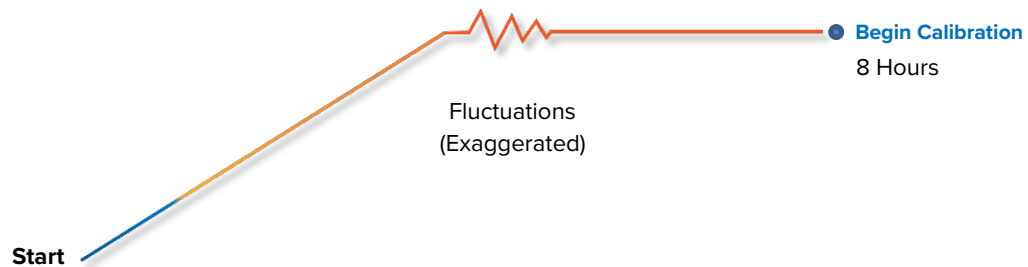


# USER MAINTENANCE

## 5) Temperature Stabilization

The incubator air temperature must stabilize in order to perform an accurate calibration.

- Allow the incubator to operate undisturbed with the door shut for **at least 8 hours** when first putting the unit into operation in a new environment.
- To be considered stabilized, the incubator chamber must operate at your calibration temperature for **at least 1 hour with no fluctuations of  $\pm 0.1^{\circ}\text{C}$  or greater.**



Required temperature stabilization period operating undisturbed with the incubator door closed.

### Suggested Temperature Calibration

1

Once the incubator temperature has stabilized, compare the reference device and incubator temperature display readings.

- If the readings are the same, or the difference between the two falls within the acceptable range of your protocol, the display is accurately showing the incubator air temperature. **The Temperature Calibration procedure is now complete.**

- Or -

- If a difference falls outside of your protocol range, advance to step 2.

Reference Device

20.0 °C

20.0 ✓

2

A display calibration adjustment must be entered to match the display to the reference device. See next step.

Reference Device

21.1 °C

20.0 ✗

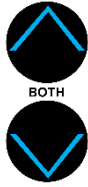
Continued next page

# USER MAINTENANCE

## Temperature Calibration Continued

3

Place the display in its temperature calibration mode.



- Press and hold both the **UP and DOWN** temperature arrow buttons simultaneously for approximately 5 seconds.
- Release the buttons when the temperature display shows the letters "C O". The display will begin flashing the **current temperature display value**.



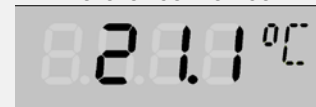
**Note:** If an arrow key is not pressed for five seconds, the display will cease flashing, and store the last displayed number as the new current chamber temperature value.

4



Use the **Up** or **Down** arrows to adjust the current display temperature value until it matches the reference device temperature reading.

Reference Device



5

After matching the display to the reference device, wait 5 seconds.



- The temperature display will cease flashing and store the corrected chamber display value.
- The incubator will now begin heating or cooling to reach the set point with the corrected display value.



Cooling to Set Point

6



**After** the incubator has achieved the corrected temperature, allow the chamber to sit at least one 1 hour undisturbed to stabilize.

- Failure to wait until the incubator is fully stabilized will result in an inaccurate reading.



Set Point Achieved

Continued next page

# USER MAINTENANCE

7

Compare the reference device reading with the chamber temperature display again.

- If the reference device and the chamber temperature display readings are the same or the difference falls within the range of your protocol, **the incubator is now calibrated for temperature.**

- OR -

- See the next step if the readings fail to match or fall outside of your protocol range.

Reference Device

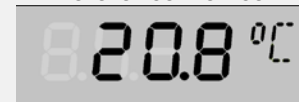


8

If the two readings are not the same, and the difference still falls outside the acceptable range of your protocol, repeat steps 3 – 7 up to two more times.

Three calibration attempts may be required to successfully calibrate units that are more than  $\pm 2^{\circ}\text{C}$  out of calibration.

Reference Device



9

If the temperature readings of the incubator temperature display and the reference device still fall outside your protocol after three calibration attempts, contact your incubator distributor or [Technical Support](#) for assistance.

End of procedure

# UNIT SPECIFICATIONS

These incubators are 220 - 240 voltage units. Please refer to the incubator data plate to verify its electrical specifications.

Technical data specified applies to units with standard equipment at an ambient temperature of 25°C and at nominal voltage. The temperatures specified are determined in accordance to factory standard following DIN 12880 respecting the recommended wall clearances of 10% of the height, width, and depth of the inner chamber. All indications are average values, typical for units produced in the series. We reserve the right to alter technical specifications at all times.

## ***WEIGHT***

Model	Shipping	Net Weight
SRI3P-2	135 lbs. / 61 kg	105.0 lbs / 47.6 kg
SRI6P-2	205 lbs. / 93 kg	125.0 lbs / 56.7 kg
SRI20P-2	405 lbs. / 184 kg	246.0 lbs / 111.6 kg

## ***DIMENSIONS***

In inches

Model	Exterior W × D × H	Interior W × D × H
SRI3P-2	24.1 x 21.3 x 33.8 in	18.9 x 16.9 x 26.4 in
SRI6P-2	30.0 x 31.5 x 33.5 in	25.5 x 24.0 x 18.5 in
SRI20P-2	30.0 x 31.5 x 69.5 in	25.5 x 24.0 x 54.5 in

In Millimeters

Model	Exterior W × D × H	Interior W × D × H
SRI3P-2	612 x 541 x 859 mm	480 x 429 x 670 mm
SRI6P-2	762 x 800 x 851 mm	648 x 610 x 470 mm
SRI20P-2	762 x 800 x 1766 mm	648 x 610 x 1384 mm

## ***CAPACITY***

Model	Cubic Feet	Liters
SRI3P-2	3.5	99.0
SRI6P-2	6.5	185.5
SRI20P-2	19.3	546.6

# UNIT SPECIFICATIONS

## *SHELF CAPACITY BY WEIGHT*

Model	Per Shelf*	Total**
SRI3P	35.0 lbs / 15.9 kg	70.0 lbs / 31.7 kg
SRI6P	75.0 lbs / 34.0 kg	150.0 lbs / 68.0 kg
SRI20P	75.0 lbs / 34.0 kg	375.0 lbs / 170.0 kg

\*Weight distributed evenly across the shelf.

\*\*Exceeding this weight limit risks damaging the shelf standard rails and the chamber liner.






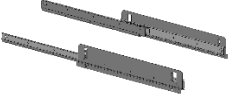
## *TEMPERATURE*

Model	Temp Range	Uniformity	Stability
SRI3P-2	15° to 40°C	±0.5° @ 20°C	±0.1°C @ 20°C
SRI6P-2	15° to 40°C	±0.5° @ 20°C	±0.1°C @ 20°C
SRI20P-2	15° to 40°C	±0.5° @ 20°C	±0.1°C @ 20°C

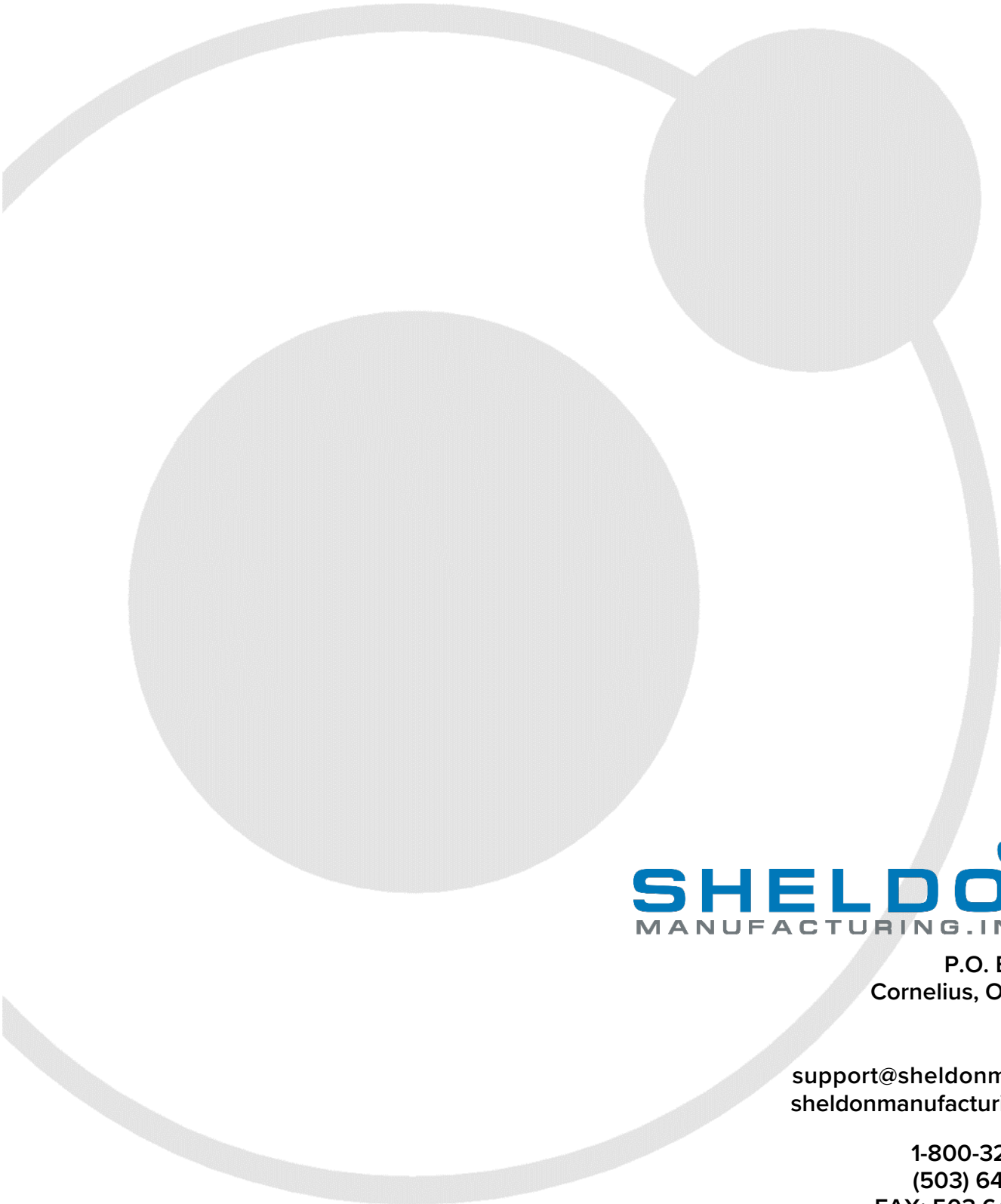
## *POWER*

Model	Voltage	Amperage	Frequency
SRI3P-2	220 - 240V	3.0	50/60 Hz
SRI6P-2	220 - 240V	3.0	50/60 Hz
SRI20P-2	220 - 240V	3.5	50/60 Hz

# PARTS AND CONSUMABLES

Description	Part Number	Description	Part Number
Access Port Stopper	 7750517	Power Cord 250 volt, 10 Amp, 2.5m (8ft), Euro CEE7/7	 1800500
Feet, Adjustable Glide	 2700506	<b>SRI3P</b> , Shelf Clip, 1	 1250512
Fuse 250V T6.3A, 5X20mm, 1 (Requires 2 for operation)	 3300515	<b>SRI3P</b> , Shelf,1	 6800529
<b>SRI3P</b> : Gasket, Magnetic Door (28.25 inches X 22.25 Inches)	 3450758	<b>SRI6P, SRI20P</b> , Shelf, 1	 6800525
<b>SRI6P</b> : Gasket, Magnetic Door (29 inches X 26 inches)	 3450743	<b>SRI6P, SRI20P</b> , Static Shelf Bracket, 1	 5220942
<b>SRI20P</b> : Gasket, Magnetic Door (29 inches X 62 inches)	 3450732	<b>SRI6P, SRI20P</b> , Sliding Shelf Brackets, 2	 9490560
Humidity Reservoir Pan, copper token, and Tubing	 9900686		

If you have the Part Number for an item, you may order the item directly from Sheldon Manufacturing by calling (503) 646-3000 Ext. 3. If you are uncertain that you have the correct Part Number or if you need that specific part, please contact Sheldon Technical Support for help at 1-800-322-4897 or (503) 640-3000 extension 4. Please have the **model number** and **serial number** of the unit ready, as Tech Support will need this information to match your unit to its correct part.



**SHELDON**  
MANUFACTURING, INC.

P.O. Box 627  
Cornelius, OR 97113  
USA

[support@sheldonmfg.com](mailto:support@sheldonmfg.com)  
[sheldonmanufacturing.com](http://sheldonmanufacturing.com)

1-800-322-4897  
(503) 640-3000  
FAX: 503 640-1366